



NAFAS

22-24 September

National Show 2011

Schedule

Amazing
Floral
Artistry



NAFAS

NATIONAL ASSOCIATION
OF FLOWER ARRANGEMENT
SOCIETIES

Riviera International Conference Centre, Torquay



Welcomes you to the
Riviera International Conference Centre, Torquay

The Events

Thursday 22 September

2.00 pm

Floral Art Demonstration

'Oh I do like to be
beside the seaside'



Barbara
Collier
£17.00

Friday 23 September

11.00 am *(no tickets
necessary)*

PRIZEGIVING

2.30 pm

Talk - 'Ancestors,
Antirrhinums and Antics'



Katherine
Kear
£9.00

Saturday 24 September

2.00 pm

Floral Art Demonstration

'Living the Dream'



Carola
Wilson
£17.00

Plus!

NAFAS trade stands

Shopping Mall *with trade and demonstration stands*

All classes in this schedule are to be regarded as exhibits

Class 1

RANDOM HARVEST

Space allowed: width 91cm,
depth 91cm, height optional.
Staged on a terracotta base 1.8cm thick.
Viewed all round and
judged from the front.

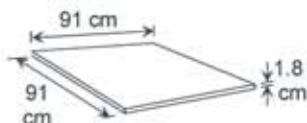

Class 2

EXPLORATION

Space allowed: quarter circle segment
89.5 cm radius, height 150 cm.
Staged on base raised 50cm from floor.
Base, background and plinth primrose.

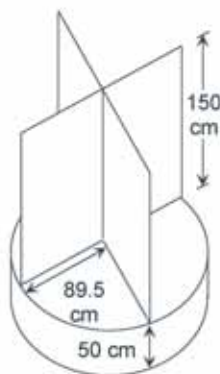

Class 3

DESTINATION UNKNOWN

Space allowed: width 97cm,
depth 75cm, height 148cm.
Staged on tabling 50cm from floor.
Staging lavender.

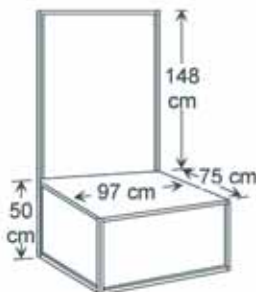

Class 4

OVERABUNDANCE

Space allowed: width 75cm,
depth 75cm, height optional.
Staged on a terracotta base 1.8cm
thick.

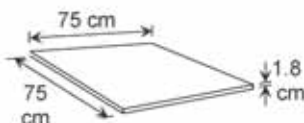

To be viewed all round and judged from the front.

Class 5

THE MUSIC OF THE SEASON IN ALL ITS PERFECTION

Space allowed: width 120cm,
depth 120cm, height optional.
Staged on a pale green base
2cm thick.

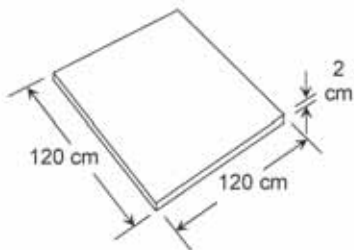

To be viewed all round and judged from
the front.

Open only to Areas of NAFAS

Class 6

PELLUCID

Petite Class

Space allowed: width 25cm,
depth 25cm, height 25cm, on tabling
120cm from floor.
Individual staging and tabling
cream.

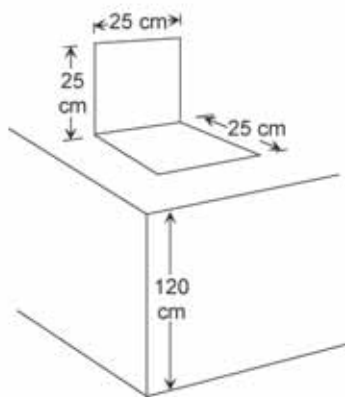

Class 7

NATIONAL HERITAGE

Space allowed: width 120cm, depth 120cm, height optional.

Staged on a grey base 0.6cm thick, title to be included.

To be viewed all round and judged from the front.

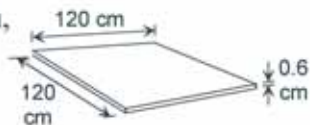

Open only to Clubs and Colleges affiliated to NAFAS

Class 8

HALCYON DAYS

Space allowed: 92cm diameter, height optional.

Staged on a lavender base 1.2cm thick.

To be viewed all round and judged from the front.



Class 9

ALTERED STATE

Space allowed: width 75cm, depth 75cm, height optional.

Staged on a terracotta base 1.8cm thick.

Staged against a beige brick wall.

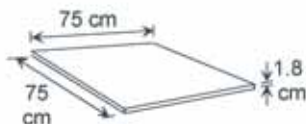

Class 10

DICHOTOMY

Space allowed: width 97cm,
depth 75cm, height 148cm.
Staged on tabling 52cm from floor.
Staging pale green.

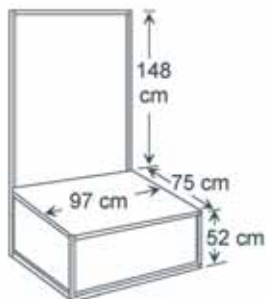

Class 11

SIMPLE PLEASURES

Space allowed: width 97cm,
depth 75cm, height 148cm.
Staged on tabling 52cm from floor.
Staging cream.

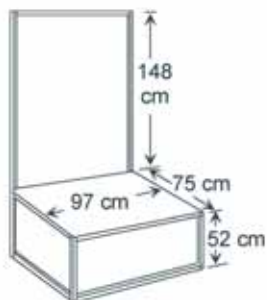

Class 12

PASSION FOR DETAIL

Craft Class

A Book Cover.

Space allowed: Width 50cm, depth 40cm,
height 20cm.

Staged on sloping tabling as shown.

Staging pale green.

May be brought in or posted ready assembled,
staged by the Competitions Committee.

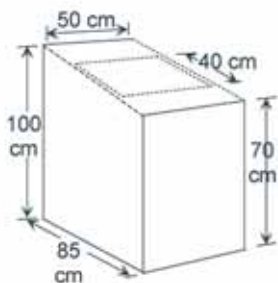

Class 13

BUCKLE UP

Craft Class:

A Decorated belt and buckle.

Space allowed: Width 40cm, depth 40cm, height 25cm.

Staged on tabling 100cm from floor.

Staging pale green.

May be brought in or posted ready assembled,
staged by the Competitions Committee.

Class 14

IMPETUS

Space allowed: width 100cm, depth 100cm,
height optional.

Staging is a plinth, width 30cm, depth 30cm,
height 120cm, with a 40cm square top, standing
on a 100cm square base.

Staging pale green.

Viewed all round and judged from the front.

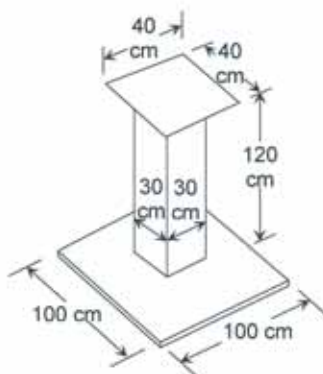

Class 15

I LIKE IT LIKE THAT

Space allowed: Width 50cm, depth 50cm, height 200cm.

Staged on 5cm vertical wire mesh, width 57.5cm, height 87.5cm.

On a metal stand, height 187.7cm.

Viewed all round and judged from the front.

Detailed drawing of stand available on acceptance of entry.

Class 16

FROM THE DEEP

Junior Craft Class 8 to 12 years.

An imaginary sea creature.

Space allowed: 30cm width, depth and height.

Staged on lavender tabling 100cm from floor.

To be brought in or posted ready assembled and staged by the Competitions Committee

Open only to Juniors affiliated to NAFAS

Class 17

FROM THE DEEP

Junior Craft Class 13 to 17 years.

An imaginary sea creature.

Space allowed: 30cm width, depth and height.

Staged on lavender tabling 100cm from floor.

To be brought in or posted ready assembled and staged by the Competitions Committee.

Open only to Juniors affiliated to NAFAS

Class 18

MODUS OPERANDI

Space allowed: width 97cm, depth 75cm, height 120cms. (from floor to top of staging). No floor placements.

Staging cream.

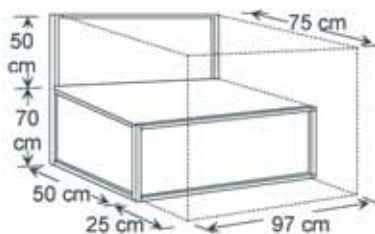

Class 19

THE REST AND QUIET RENEWAL OF WINTER

Space allowed: width 97cm,
depth 75cm, height 130cm.
Staged on tabling 70cm from floor.
Staging grey.

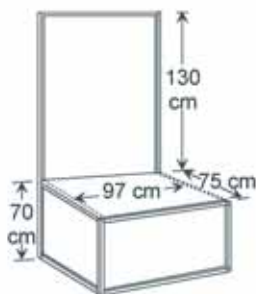

Class 20

THE BEAUTY OF THE NIGHT

Space allowed: width 97cm,
depth 50cm, height 130cm.
Staged on tabling 70cm from floor.
Staging grey.

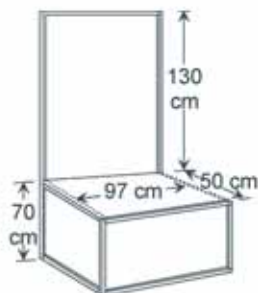

Class 21

A MIST OF COLOUR

Space allowed: width 70cm, depth 40cm,
drop 150cm, to hang from a hook 200cm from floor.
Staging grey metal frame width 97cm,
depth 47cm, height 200cm.
Maximum weight 25kgs.
Staged against beige brick wall.
Detailed drawing will be sent with acceptance of entry.

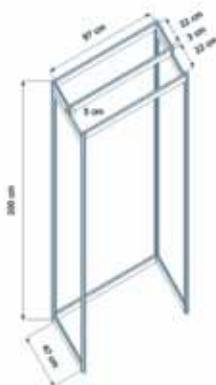

Class 22

STREAMLINED

Space allowed: width 45cm,
depth 45cm, height optional.
Staged on tabling 50cm from floor
against a beige brick wall.
Staging cream.

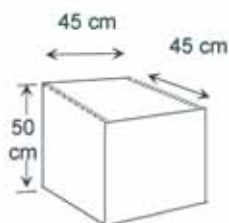



NAFAS

National Show 2011

Panel of Accredited National Judges

Alan Beatty
Jackie Charnock
Christina Curtis
Pam Fleming-Williams
Barbara Harris
Pat Hutchinson
Janet James
Anne Jennings
Christine Picton
Pat Reader

Arbitrators

Judith Taylor NAFAS Judging Committee Chairman
Lois Gill NAFAS Judging Committee Vice Chairman

Reserve Judges

Deborah Hutton
Brid Kelleher

Riviera International Conference Centre, Torquay

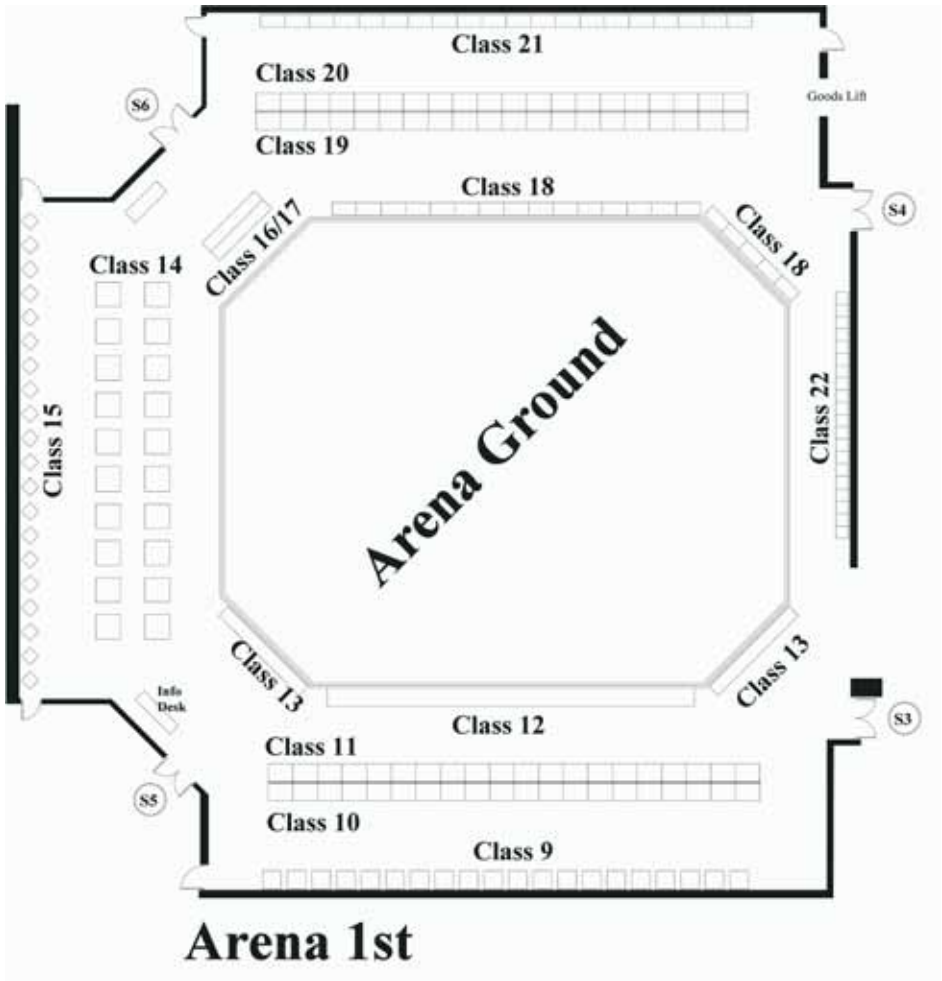



NAFAS

National Show 2011



REGULATIONS

General

1. The Competitions are open to members of Clubs and Societies affiliated to any of the Area Associations of NAFAS, including International Affiliates, Overseas Members of the London and Overseas Area of NAFAS, members of a Flower Association affiliated to a WAFSA affiliated country and to individual members of NAFAS.

Class 7 is also open to Affiliated Colleges.

2. All exhibits will be judged in accordance with the *NAFAS Competitions Manual – Second Edition 2009*.
3. **All exhibits must be the unaided work of the competitor and must be assembled in the hall** with the exception of Craft Classes 12 and 13 for which exhibits may be submitted ready assembled. See also Regulation 15.

Items requiring special time or expertise for their preparation may be brought assembled for incorporation in the exhibit, though **these items must not be predominant in the exhibit. This ruling will be actively monitored throughout staging and relevant information given to the Arbitrators and Judges.**

4. Any complaint by competitors should be handed to the Competitions Officer in writing before the end of staging at 2.30 pm on Wednesday 21 September. The decision of the Judges is final.
5. All exhibits and competitors property will be at the risk of the competitor and neither NAFAS nor the owners or occupiers of the premises in which the Competitions, or any part of them, are held can accept any liability whatsoever for any loss or damage sustained by any competitor.
6. **Area and Club Entries**
 - A These must be on the official entry forms accompanied by a fee of £50.00 (Area) or £35.00 (Club).
 - B These entries must reach the Competitions Officer **not before 25 April and not after 2 May 2011**

- C Affiliated Colleges may enter Class 7 only.
- D Envelopes containing Area, Club or College entries must be marked **AREA, CLUB or COLLEGE** on the top left-hand corner and must include a self-addressed adhesive label suitable for an A5 envelope. A stamped addressed envelope must be enclosed with any subsequent correspondence.

7. Individual Entries

- A Individual entries must be on the official entry forms accompanied by a fee of £25 for the first entry and, if applicable, a separate cheque of £10 for the second entry.
- B Individual entries must reach the Competitions Officer **not before 2 May and not after 16 May 2011**
- C Competitors may not enter more than two classes. Competitors may stage only one entry per class.
- D Alternative choices may be made as indicated on the entry form.
- E Envelopes containing individual entries should be marked **INDIVIDUAL** on the top left-hand corner and must include a self-addressed adhesive label suitable for an A5 envelope. A stamped addressed envelope must be enclosed with any subsequent correspondence.
- F Competitors will be advised of the acceptance of entries as soon as possible after the closing date. If a class is over-subscribed entries will be allocated by ballot. Acceptance of all entries must be returned within ten days.
- G **PLEASE NOTE: CLASSES 9-22 ARE ON THE BALCONY. THERE IS A LARGE LIFT AVAILABLE.**

8. Junior Entries

- A No entry fees are required for the Junior classes.
- B If Junior classes are oversubscribed the number of entries from any one group may be restricted.

9. Entry fees are non-returnable.

Staging

10. Competitors must wear their badges at all times.
11. The Competitions Committee will decide the positions of all exhibits.
12. The location of classes can be found within the Schedule. Details of staging, if applicable, will be sent with acceptance of entries.
13. A maximum of **two** members allowed for staging Area exhibits; two members for staging Club and Affiliated College exhibits; individual competitors only in all other classes.
14. Only officials, competitors and other authorised persons will be allowed in the halls during staging times.
15. In Craft Classes 12, 13, 16 and 17
 - A A competitor's exhibit may be posted to
The Competitions Officer
14 Glencraig Park
Holywood
Co. Down
BT18 0BZ
to arrive between 5 September and 12 September
 - B A competitor's exhibit may be handed to the Competitions Officer between 8.30 pm and 9.30 pm on Tuesday 20 September or between 7.00 am and 10.00 am on Wednesday 21 September 2011
Exhibits will be staged by the Competitions Committee.
16. All exhibits will be staged in artificial lighting.
17. All measurements in the staging instructions are approximate.
All exhibits must be staged **within the space provided**.
18. Colour samples of staging will be sent on acceptance of entry.
Unless otherwise instructed, nothing may be attached to the staging in any class.
19. Aerosol cans of any description must not be used in the competition halls.
Competitors may use glue guns and other electrical equipment only when accompanied by a valid PAT certificate.

20. Competitors will be responsible for the maintenance of their exhibits during the three days the Show is open to the public. A half-hour each day will be allowed for maintenance before the Show opens to the public. The Competitions Committee reserve the right to move and/or replace any plant material.

21. **Staging** Wednesday 21 September 6.30 am to 2.30 pm
Subject to completion by contractors, competitors will be allowed to **unload only** on Tuesday 20 September 8.00 pm to 9.30 pm. Please refer to **Information for Competitors** for further details of unloading times as these may be staggered to alleviate congestion.

22. **Judging** Wednesday 21 September 3.30 pm to 9.30 pm

23. **Dismantling** Saturday 24 September 5.45 pm to 6.45 pm
All competitors and visitors will leave the hall, the exhibits remaining intact. Competitors may collect a badge to admit one person to assist in dismantling their exhibit(s). When the hall is empty, the competitors and assistants will be re-admitted.
Competitors must ensure that all rubbish is removed from the Hall.

24. **Presentation of Prizes**

Trophies awarded at the Competitions will be presented at the prize-giving. A colour photograph of the presentation of the trophy will be taken and sent to the recipient.

Trophies are to be left with the Competitions Officer for return to National Headquarters.

Presentation of Prizes

The Forum

by Pat Martin President of NAFAS

at 11.00 am on Friday 23 September 2011

Further copies of the schedule and additional information
are available from the Competitions Officer

Margaret Abernethy
14 Glencraig Park
Holywood
County Down
BT18 0BZ

Tel: 028 9042 2117 E-mail: kenmar60@btinternet.com

Please send a SAE not less than 229 mm x 162 mm (C5)

The schedule may also be downloaded from the NAFAS website
www.nafas.org.uk

Light refreshments will be available during staging hours
and refreshments will be available throughout the Show.

NAFAS NATIONAL SHOW TORQUAY 2011

AWARDS

The Best Individual Exhibit in the Show (excluding Classes 5,7,12,13,16 and 17) will be awarded the Julia Clements Challenge Trophy.

The Runner-Up to the Best Individual Exhibit in the Show (excluding Classes 5,7,12,13,16 and 17) will be awarded the Antique Silver Wine Cooler presented as a Challenge Trophy by the late Mrs Mary Pope OBE, VMH, Founder President of NAFAS.

The Wafa Award. The winner or runner-up of the Best Individual Exhibit in the Show will be eligible for sponsorship at the Wafa Show 2014 (terms and conditions available on request).

The Fresh Garden Plant Material Trophy presented as a Challenge Trophy by the late Mrs C. A Yates will be awarded to the exhibit which best emphasises the use of fresh garden plant material.

The Robert Gibbs Trophy presented as a Challenge Trophy by the late Mrs Veronica Gibbs, Past President of NAFAS, will be awarded to the exhibit which best emphasises the use of foliage.

The NAFAS Colour Trophy presented as a Challenge Trophy by the late Mr Bill Lomas will be awarded to the exhibit which best emphasises the use of colour.

The NAFAS Texture Trophy presented as a Challenge Trophy by Mrs Joan Cooper, Past President of NAFAS, will be awarded to the exhibit which best emphasizes the use of texture.

A Gold Ribbon will be awarded to any competitor who wins a first prize in each of three consecutive years at National Shows. Only one first prize will be accepted each year from any competitor towards the Gold Ribbon.

NAFAS Spoons (gold, silver-gilt and silver) will be awarded in each class except Classes 5,7,16 and 17.

NAFAS Medals (gold, silver and bronze) will be awarded in Classes 5 and 7.

In the following classes the winners will receive:

- Class 1 Challenge Trophy presented by the late Mr Robert Randall
- Class 2 Challenge Trophy presented by the late Mrs Mary Barnard, Past President of NAFAS.
- Class 3 Revere Challenge Trophy and Affiliates Citation presented by the National Council of State Garden Clubs Inc. of the United States of America. The citation to be retained by the winner.
- Class 4 Challenge Trophy presented by the late Mrs S. E. Pullan.
- Class 5 Pair of Sheffield Plate Candlesticks presented as a Challenge Trophy by the late Mrs Elsie Lamb.
- Class 6 Challenge Trophy presented by the late Mrs Mary D. Graves, Past President of NAFAS. The second prize winner will receive a Challenge Trophy presented by the Northern Ireland Group of Flower Arrangement Societies.
- Class 7 Silver Challenge Trophy in memory of Mrs Constance Spry.
- Class 8 Challenge Trophy presented in memory of Mrs Marion Aaronson.
- Class 9 Challenge Trophy presented by Mrs Mary R. Law MBE, Past President of NAFAS.
- Class 10 Challenge Trophy presented by the late Mrs H. W. Hall.
- Class 11 Silver Rose Bowl Trophy donated by *Garden News*.
- Class 12 Brunskill Trophy presented as a Challenge Trophy by the late Mrs Gerald Brunskill, Past President of NAFAS.
- Class 13 Edinburgh Cup presented as a Challenge Trophy by Mrs Dorothy Cook, Life Vice-President of NAFAS.
- Class 14 Challenge Trophy presented by the late Mrs Mary Napper, Past President of NAFAS.

- Class 15 Challenge Trophy presented by Mrs Evelyn Mercer, Past President of NAFAS.
- Class 16 Junior Challenge Trophy presented in memory of the late Mrs Patricia Knight. The prize winners will each receive a gift token.
- Class 17 Junior Challenge Trophy presented by the late Mrs Margaret Keith, Past President of NAFAS. The prize winners will each receive a gift token.
- Class 18 Challenge Trophy presented by the late Mrs Jean Taylor.
- Class 19 Antique Ormolu Tazza mounted on a marble plinth presented as a Challenge Trophy by the late Mrs Mary Pope OBE, VMH, Founder President of NAFAS.
- Class 20 Challenge Trophy and a NAFAS Silver Pendant presented by the late Mrs Joan Newlyn, Past Chairman of NAFAS. The pendant to be retained for one year.
- Class 21 The Flower Arranger Award. A three-year subscription with binder, to the *The Flower Arranger*, presented by the Editorial Board.
- Class 22 NAFAS Silver Jubilee Challenge Trophy presented by Past Officers of the Association.

Photography

1st, 2nd, 3rd and Special Award Exhibits will be photographed by the official photographers under the direction of the National Photography Committee.

Photography of the exhibits will not be allowed unless a permit has been obtained. Permits can be purchased in the hall and must be displayed. Only hand held cameras without separate lighting, tripods or other supports, may be used. Video cameras will not be permitted.

Permission for photography is only given on the understanding that photographs will not be reproduced without the written consent of NAFAS.

NAFAS reserves the right to reproduce any photograph taken at this event in any publication.

The Tickets

Tickets are available, from the end of October 2010
by post from: **Mrs Silvana Gray-Perry**
15 Mapleton Road, Wigston, Leicester LE18 1DW
Tel: 0116 288 2107

Daily Admission	Thu	Fri	Sat
Advance booking	£14.00	£14.00	£14.00
Group booking (25+) *	£12.00	£12.00	£12.00
At the Show	£16.00	£16.00	£16.00
Season Ticket	£28.00		

* Coaches need to be booked

The Times

Thursday 22 September 9.30am - 6.00pm
Friday 23 September 9.30am - 6.00pm
Saturday 24 September 9.30am - 5.30pm



Demonstrations sponsored by:
European Connoisseurs Travel Ltd



Floral Foam and Sundries supplied by:
Oasis Floral Products

For more information you can:
visit our website: **www.nafas.org.uk**
or call us: **0121 705 4126**

For accommodation during the Show, contact:
Conference Torquay
Riviera International Conference Centre
Chestnut Avenue, Torquay, Devon, TQ2 5LZ
Tel: 01803 206 306
Email: accommodation@conferencetorquay.co.uk
NAFAS accepts no liability for any accommodation bookings.

ECT Travel

European Connoisseurs Travel

European Connoisseurs Travel

With a commitment to continued sponsorship of **NAFAS**, we have contributed over £25000, supporting the 50th anniversary, Area Days, the National Show and individual publications.



NEED SOME INSPIRATION FOR YOUR NEXT GROUP VISIT?

**ART GALLERIES
CHRISTMAS MARKETS
CLASSIC TOURS
FLORISTRY & GARDENS
MUSIC FESTIVALS
SHOPPING, FOOD, WINE TASTING**

ECT offers a broad selection of event-based tours, tailored to your interests.



Some special tours to consider:

- **This Glorious Earth - 10th World Flower Show in Boston**
15-19 June 2011 – organised by Wafa, USA
- **Floriade 2012 World Horticultural Expo, Venlo, NL**
April-mid October 2012
Held once every 10 years, this spectacular event will provide a full cultural and floral programme not to be missed.



Please contact Theresa McDermott at:

EUROPEAN CONNOISSEURS TRAVEL LTD

1 The Stables | Priston Mill Farm | Priston Mill | Bath BA2 9EQ

T: 0800 2980588 E: sales@ecttravel.com

www.ecttravel.com

Affordable, Luxury Coach Travel to EU and UK destinations



National Show 2011

RIVIERA CENTRE TORQUAY

Area Entry Form

THE MUSIC OF THE SEASON IN ALL ITS PERFECTION

We wish to enter Class 5 THE MUSIC OF THE SEASON IN
ALL ITS PERFECTION

Name of Area

(In block letters as it is to be printed)

Name and address for correspondence

(Please print)

.....

Post code Tel. no. (with code)

Email

Names of arrangers (max TWO)

(Please print – first and surname)

.....

.....

Signed Area Chairman

We enclose a cheque for £50 made payable to **NAFAS Show TORQUAY**

Your entry must be marked **AREA** in the top left-hand corner of the envelope and must include a **self-addressed adhesive label** suitable for an A5 envelope.

This form to be returned with your cheque between 25 April and 2 May 2011
– **NOT BEFORE AND NOT AFTER** – to: The Competitions Officer,
Margaret Abernethy 14 Glenraig Park, Holywood, Co Down, BT18 0BZ
(Allow 21 days from closing date for reply)

NATIONAL ASSOCIATION OF FLOWER ARRANGEMENT SOCIETIES
Osborne House, 12 Devonshire Square, London EC2M 4TE
Registered Charity No. 1101348